



# LUXSOLAR® CATALOGUE

**IALA Marine Navigation Aids**

rev\_250129



[www.luxsolar.com](http://www.luxsolar.com)

Luxsolar® is a department  
of CE2K S.r.l.



*Luxsolar and LXS are department of CEZK S.r.l., a company that since 1988 produces special equipment for the Oil&Gas Industry. Working in this sector, we realized that there was an increasing need of reliable lighting systems, suitable for dangerous and potentially explosive atmospheres.*

*In 2005, to satisfy the specific demand of LED Aircraft Warning Lights, CEZK S.r.l. created Luxsolar.*

*Today, after a decade marked by a stable and growing global market presence, Luxsolar has become the first manufacturer of Aircraft Warning Lights that, using LED technology, can offer a complete range from low intensity LIOL (10cd) to high intensity HIOL (270.000cd - 360°). After several and successful years in the Aircraft Warning Light systems, we decided to increase our target and offer to our consolidate customers and new customers also LED beacons suitable for the marine field. This range is currently increasing with new products that will be add soon to the existing beacons. The marine beacons that are part of our range are IALA (International Association of Marine Aids to Navigation and Lighthouse Authorities) compliant as per the association's guidelines and recommendations.*

*Design and Quality are important to Luxsolar, as well as the possibility to rely on a network of certified American and European suppliers. All the products are designed and manufactured at the company headquarter in Oggiono, Italy.*

*Luxsolar and LXS products are submitted to a constant improvement process, thanks to an intense R&D activity conducted both independently and in collaboration with major Universities and Research Centres.*

*Thanks to its ability to offer individual solutions for customers and to produce lighting systems compliant to local and international regulations, Luxsolar processes purchase orders from around the world.*

*Luxsolar mission is to create more and more sustainable products, thanks to a constant innovation in the field of light signalling devices.*

A handwritten signature in black ink, appearing to read 'Roberto', is positioned above the Luxsolar logo.

**LUXSOLAR**

*#everything is made for passion*

## INDEX

### MARINE NAVIGATION AIDS - SAFE AREA IPXX

Product Line for Safe area IPXX.....	5
15nM white light night mode .....	6
10nM white light night mode .....	9
5nM red light night mode .....	12
3nM red light night mode .....	16
LIGHTHOUSE LIGHTS	
▶Product Line for Safe area IP66.....	21
▶White lighthouse ligh.....	22
▶Green lighthouse light .....	26
▶Red lighthouse light .....	30

### MARINE NAVIGATION AIDS - EXPLOSION PROOF AREA

Product Line fot Explosion proof area .....	35
15nM white light Ex night mode .....	36
10nM white light Ex night mode .....	40
5nM red light Ex night mode.....	44
3nM red light Ex night mode.....	48

### CONTACTS

C&E S.r.l .....	55
-----------------	----





# MARINE NAVIGATION AIDS

## PRODUCT LINE TYPICAL INSTALLATION SURFACE LEVEL MARINE NAVIGATION AIDS

SAFE AREA IP66

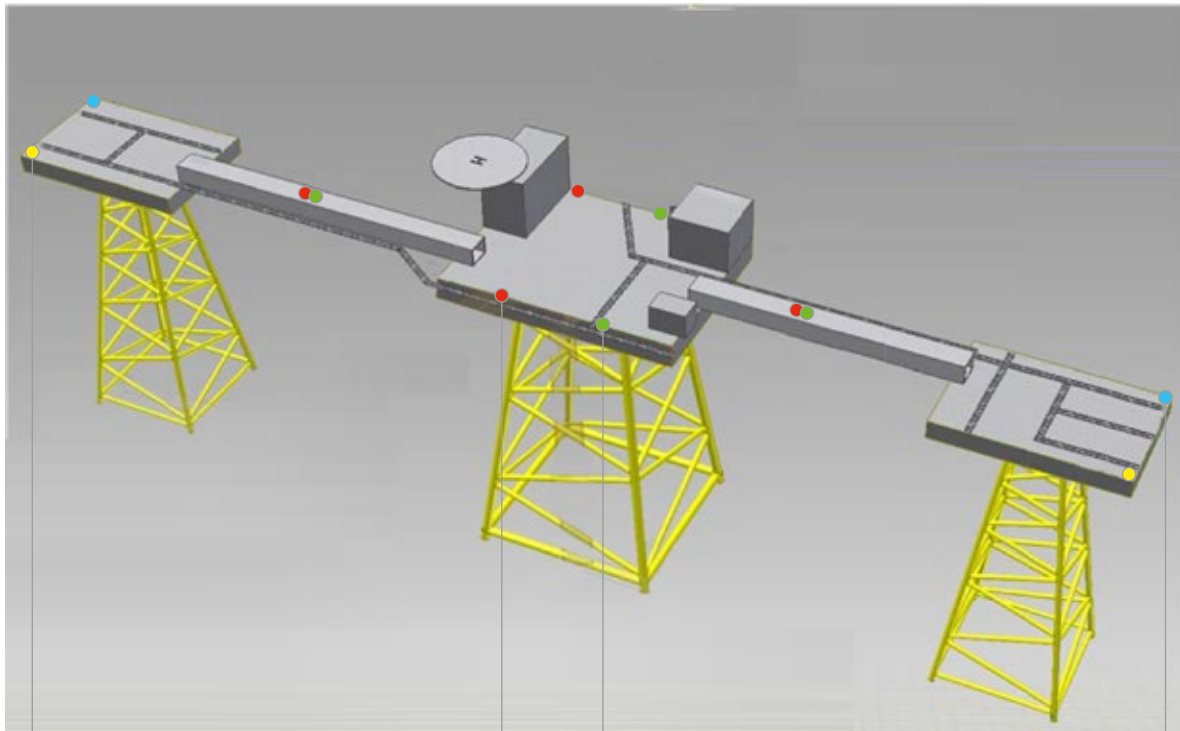

15NM WHITE LIGHT  
NIGHT MODE



5NM WHITE LIGHT  
NIGHT MODE



3NM WHITE LIGHT  
NIGHT MODE



10NM WHITE LIGHT  
NIGHT MODE



### LEGEND

- |   |                             |   |                          |
|---|-----------------------------|---|--------------------------|
|  | 15NM WHITE LIGHT NIGHT MODE |  | 5NM RED LIGHT NIGHT MODE |
|  | 10NM WHITE LIGHT NIGHT MODE |  | 3NM RED LIGHT NIGHT MODE |

Image is for informational purposes only.

## 15nM WHITE LIGHT NIGHT MODE

SAFE AREA IP66



# MARINE NAVIGATION AIDS

## 15nM WHITE LIGHT NIGHT MODE TECHNICAL SPECIFICATIONS

### KEY FEATURES

- Based on LED technology
- 15nM (nautical mile) night mode, white flashing (Morse Letter "U")
- Long life time >10 years life expectancy
- Low consumption
- Stabilised light output
- Lightweight and compact
- Low wind load factor
- Alarm/remote status control
- Easy to install
- No RF-radiations
- Light output alignment device
- Patented beacon ( EU 001929910-0001; Canada 145 189; USA D673,474)

### OPTICAL FEATURES

- Horizontal beam radiation 360°
- Vertical beam spread >2,5°
- PMMA lens

### OPTIONS

- Power supply AC or DC

### ELECTRICAL FEATURES

- Power supply for external control
- Average power consumption for night mode: 18W
- LED feeded at constant current
- Lightning protection inside controller

### MECHANICAL FEATURES

- Anodised aluminium body with heat-sink for natural draft air cooling
- RAL7035 painted aluminium body lamp
- Bottom wind collector for central heat-sink cooling
- Borosilicate glass cover protection
- Silicon gasket
- Degree of protection: IP65
- Operating temperature: -50°C to +80°C
- Storage temp. range: -20°C to +45°C
- Lamp unit weight: 6kg

### APPLY TO

- Offshore structures classified as safe areas
- Isolated wind turbine, beacon is located at not less than 6m and not more than 30m above Highest Astronomical Tide (HAT)
- Meteorological mast
- Other individual structure
- Used as main light to ensure that at least one light is visible upon approaching the structure from any direction

### INTERNATIONAL REGULATION

- IALA Maritime Buoyage System (MBS)
- IALA Recommendation O-139 2<sup>nd</sup> Edition, December 2013
- Standard marking schedule for offshore installations, Dec 04/11
- CE marking

### PART NUMBER

- Part number:
  - ▶ MNL-LXS-15nM-230VAC
  - ▶ MNL-LXS-15nM-24VDC

# MARINE NAVIGATION AIDS

## 15nM WHITE LIGHT NIGHT MODE

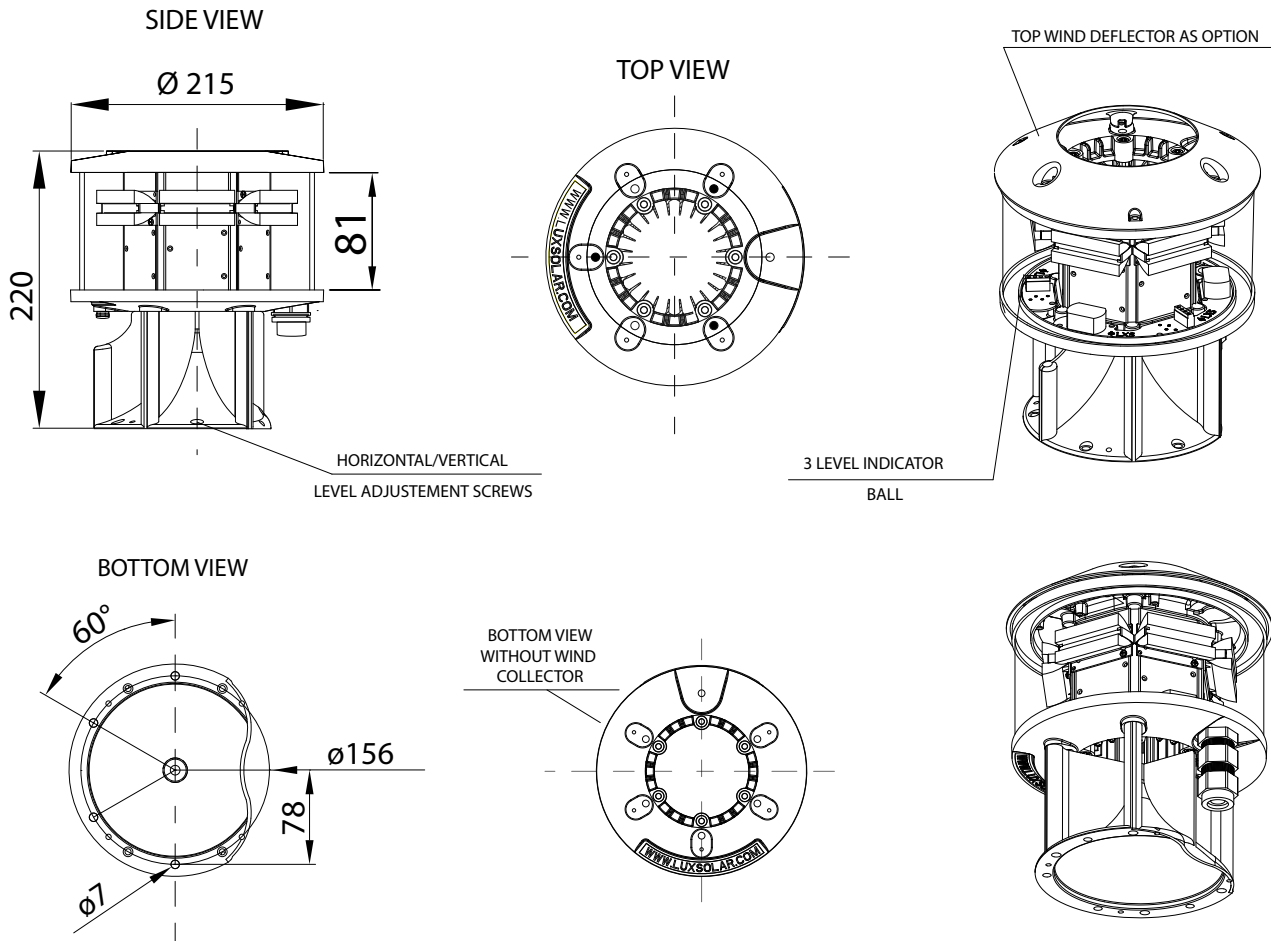

### CERTIFICATIONS



### FEATURES



### TYPICAL APPLICATION





## 10nM WHITE LIGHT NIGHT MODE

SAFE AREA IP66



# MARINE NAVIGATION AIDS

## 10nM WHITE LIGHT NIGHT MODE TECHNICAL SPECIFICATIONS

### KEY FEATURES

- Based on LED technology
- 10nM (nautical mile) night mode, white flashing (Morse Letter "U")
- Long life time >10 years life expectancy
- Low consumption
- Stabilised light output
- Lightweight and compact
- Low wind load factor
- Alarm/remote status control
- Easy to install
- No RF-radiations
- Light output alignment device
- Patented beacon ( EU 001929910-0001; Canada 145 189; USA D673,474)

### OPTICAL FEATURES

- Horizontal beam radiation 360°
- Vertical beam spread >2,5°
- PMMA lens

### OPTIONS

- Power supply AC or DC

### ELECTRICAL FEATURES

- Power supply for external control panel
- Average power consumption for night mode: 6W
- LED feeded at constant current
- Lightning protection inside controller

### MECHANICAL FEATURES

- Anodised aluminium body with heat-sink for natural draft air cooling
- RAL7035 painted aluminium body lamp
- Bottom wind collector for central heat-sink cooling
- Borosilicate glass cover protection
- Silicon gasket
- Degree of protection: IP66
- Operating temperature: -50°C to +80°C
- Storage temp. range: -20°C to +45°C
- Lamp unit weight: 6kg

### APPLY TO

- Offshore structures classified as safe areas
- Isolated wind turbine, beacon is located at not less than 6m and not more than 30m above Highest Astronomical Tide (HAT)
- Meteorological mast
- Other individual structure
- Used as main light to ensure that at least one light is visible upon approaching the structure from any direction

### INTERNATIONAL REGULATION

- IALA Maritime Buoyage System (MBS)
- IALA Recommendation O-139 2<sup>nd</sup> Edition, December 2013
- Standard marking schedule for offshore installations, Decc 04/11
- CE marking

### PART NUMBER

- Part number:
  - ▶ MNL-LXS-10nM-230VAC
  - ▶ MNL-LXS-10nM-24VDC

# MARINE NAVIGATION AIDS

## 10nM WHITE LIGHT NIGHT MODE

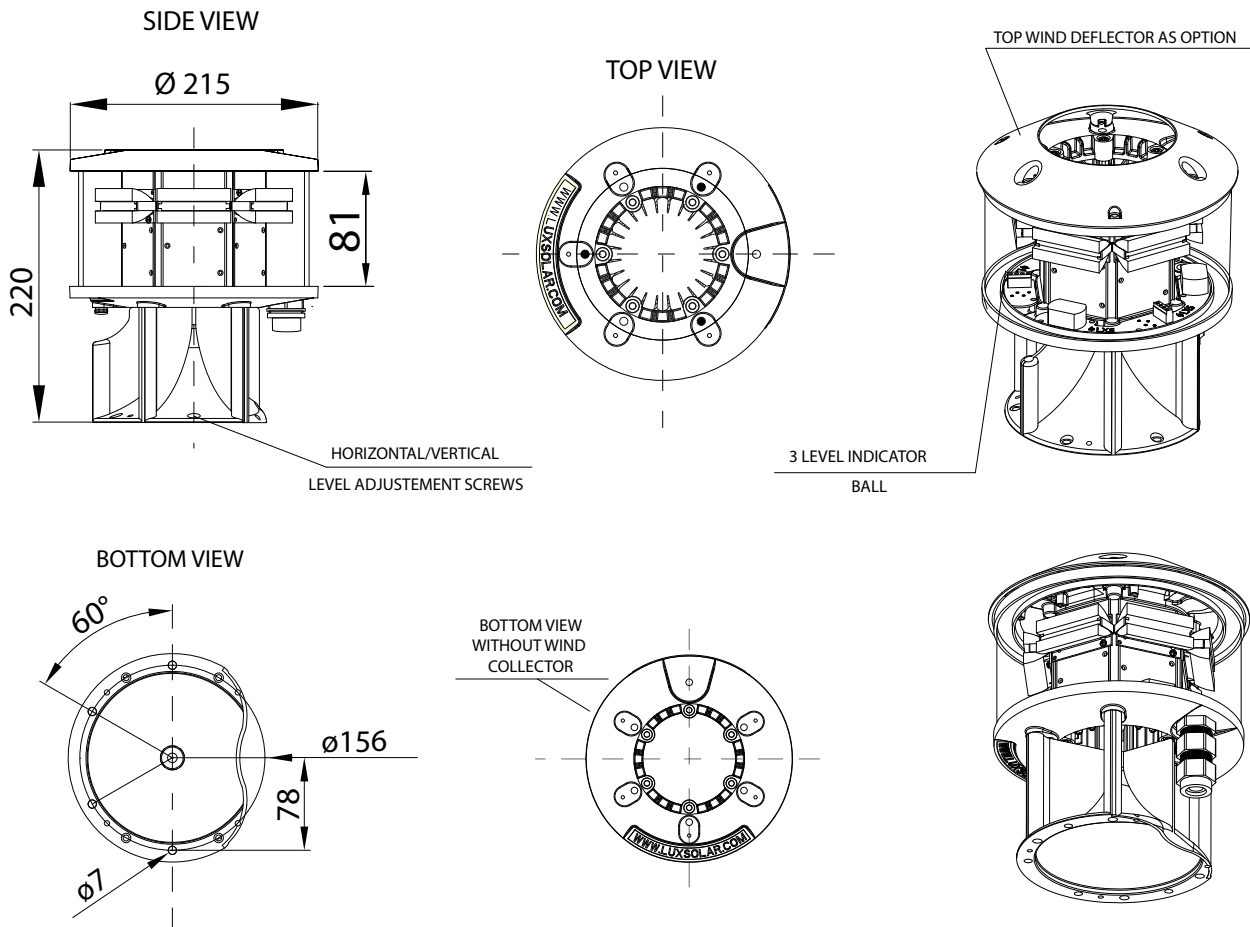

### CERTIFICATIONS



### FEATURES



### TYPICAL APPLICATION



## 5nM RED LIGHT NIGHT MODE

SAFE AREA IP66



# MARINE NAVIGATION AIDS

## 5nM RED LIGHT NIGHT MODE

Polycarbonate UV resistant dome

Twilight sensor\*

Stabilised light output  
LIOL-A: >10cd  
LIOL-B: >32cd  
LIOL-E: >32cd

- ▶ Standard circuits or TWIN\*
- ▶ Infrared version\*

Based on LED technology  
Red flashing light (FAA)  
Red steady burning light (ICAO-FAA)

Polyurethane foam

Anti-condensation  
Gore-Tex valve

Anodised aluminium body  
with heat-sink pins

Thread 3/4" F NPT

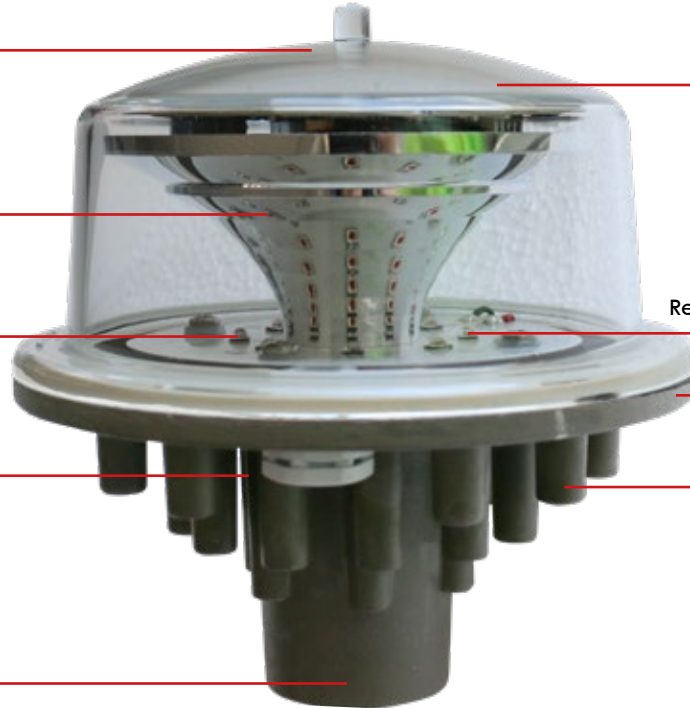

\*as option

## INTERNATIONAL PATENTS: GRANTED AND PENDING

The Auxiliary night beacons "MNL-LXS-5NM" is used for structures located in a safe area, to support Primary beacons to defining the obstacle.

The Auxiliary signaling beacons are installed at the ends of the structures only if the primary signaling beacons are not sufficient (for example, connection bridges between several platforms).

The structures that are generally signalled with these night lights, which provide visibility from 5 nautical miles away, are: large offshore platforms and other individual structures placed in navigable waters.

### CERTIFICATIONS



### FEATURES



### TYPICAL APPLICATION



# MARINE NAVIGATION AIDS

## 5nM RED LIGHT NIGHT MODE TECHNICAL SPECIFICATIONS

### KEY FEATURES

- Based on LED technology
- 5nM (nautical mile) night mode, red flashing (Morse Letter "U")
- Long life time >10 years life expectancy
- Low consumption
- Stabilised light output
- Lightweight and compact
- Low wind load factor
- Alarm/remote status control
- Easy to install
- No RF-radiations
- Light output alignment device
- Patented beacon:  
(Germany 20 2011 107 787.3;  
France 1160162)

### OPTICAL FEATURES

- Horizontal beam radiation 360°
- Vertical beam spread >2,5°
- PMMA lens

### OPTIONS

- Power supply AC or DC

### ELECTRICAL FEATURES

- Power supply for external control panel
- Average power consumption for night mode: 4W
- LED feeded at constant current
- Lightning protection inside controller

### ORDER CODE

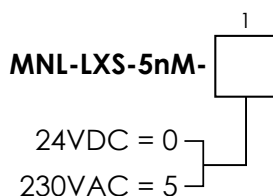

### MECHANICAL FEATURES

- Anodised aluminium body with heat-sink pins on the bottom
- Polycarbonate UV Resistant Dome
- Silicon gasket
- Degree of protection: IP66
- Operating temperature: -20°C to +50°C
- Storage temperature: -20°C to +50°C
- Lamp unit weight: 1kg

### APPLY TO

- Offshore structures classified as safe areas.  
Use as subsidiary light located to mark the horizontal extremities of the structure excepting those mark with white lights as well as interconnecting bridges.

### CERTIFICATIONS

- IALA Maritime Buoyage System (MBS)
- IALA Recommendation O-139 2<sup>nd</sup> Edition, December 2013
- Standard marking schedule for offshore installations, Decc 04/11
- CE marking

# MARINE NAVIGATION AIDS

## 5nM RED LIGHT NIGHT MODE

### WALL MOUNTING AND JB

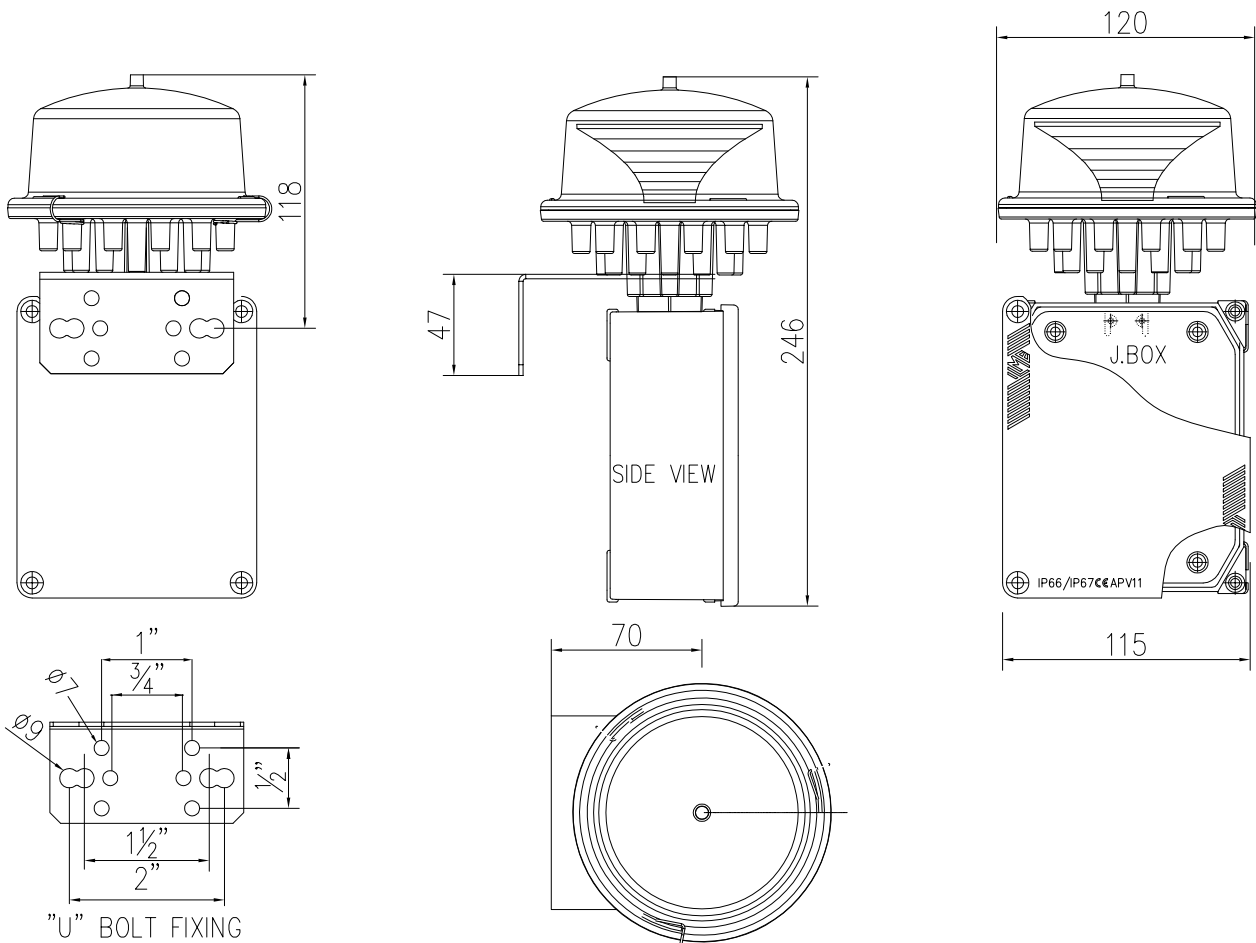

## 3nM RED LIGHT NIGHT MODE

SAFE AREA IP66





# MARINE NAVIGATION AIDS

## 3nM RED LIGHT NIGHT MODE

Polycarbonate UV resistant dome

Twilight sensor\*

Stabilised light output

LIOL-A: >10cd

LIOL-B: >32cd

LIOL-E: >32cd

- ▶ Standard circuits or TWIN\*
- ▶ Infrared version\*

Based on LED technology  
Red flashing light (FAA)  
Red steady burning light (ICAO-FAA)

Polyurethane foam

Anti-condensation  
Gore-Tex valve

Anodised aluminium body  
with heat-sink pins

Thread 3/4" F NPT

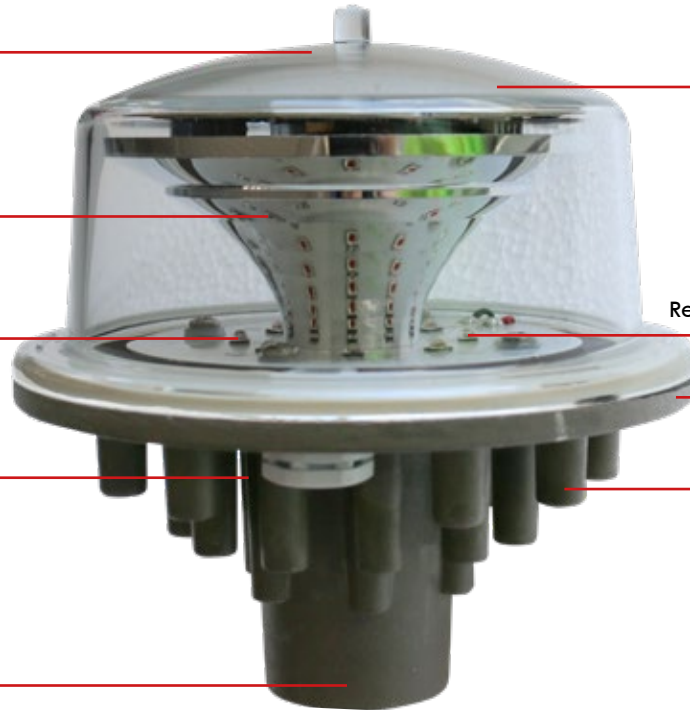

\*as option

## SEVERAL INTERNATIONAL PATENTS: GRANTED AND PENDING

The Auxiliary night beacons "MNL-LXS-3NM" is used for structures located in a safe area, to support Primary beacons to defining the obstacle.

The Auxiliary signaling beacons are installed at the ends of the structures only if the primary signaling beacons are not sufficient (for example, connection bridges between several platforms).

The structures that are generally signalled with these night lights, which provide visibility from 3 nautical miles away, are: large offshore platforms and other individual structures placed in navigable waters.

### CERTIFICATIONS



### FEATURES



### TYPICAL APPLICATION



# MARINE NAVIGATION AIDS

## 3nM RED LIGHT NIGHT MODE TECHNICAL SPECIFICATIONS

### KEY FEATURES

- Based on LED technology
- 3nM (nautical mile) night mode, red flashing (Morse Letter "U")
- Long life time >10 years life expectancy
- Low consumption
- Stabilised light output
- Lightweight and compact
- Low wind load factor
- Alarm/remote status control
- Easy to install
- No RF-radiations
- Light output alignment device
- Patented beacon:  
(Germany 20 2011 107 787.3;  
France 1160162)

### OPTICAL FEATURES

- Horizontal beam radiation 360°
- Vertical beam spread >2,5°
- PMMA lens

### OPTIONS

- Power supply AC or DC

### ELECTRICAL FEATURES

- Power supply for external control panel
- Average power consumption for night mode: 2W
- LED feeded at constant current
- Lightning protection inside controller

### ORDER CODE

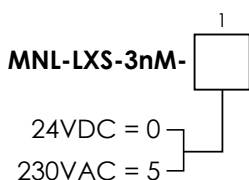

### MECHANICAL FEATURES

- Anodised aluminium body with heat-sink pins on the bottom
- Polycarbonate UV Resistant Dome
- Silicon gasket
- Degree of protection: IP66
- Operating temperature: -20°C to +50°C
- Storage temperature: -20°C to +50°C
- Lamp unit weight: 1kg

### APPLY TO

- Offshore structures classified as safe areas.  
Use as subsidiary light located to mark the horizontal extremities of the structure excepting those mark with white lights as well as interconnecting bridges.

### CERTIFICATIONS

- IALA Maritime Buoyage System (MBS)
- IALA Recommendation O-139 2<sup>nd</sup> Edition, December 2013
- Standard marking schedule for offshore installations, Dec 04/11
- CE marking

# MARINE NAVIGATION AIDS

## 3nM RED LIGHT NIGHT MODE

### WALL MOUNTING AND JB

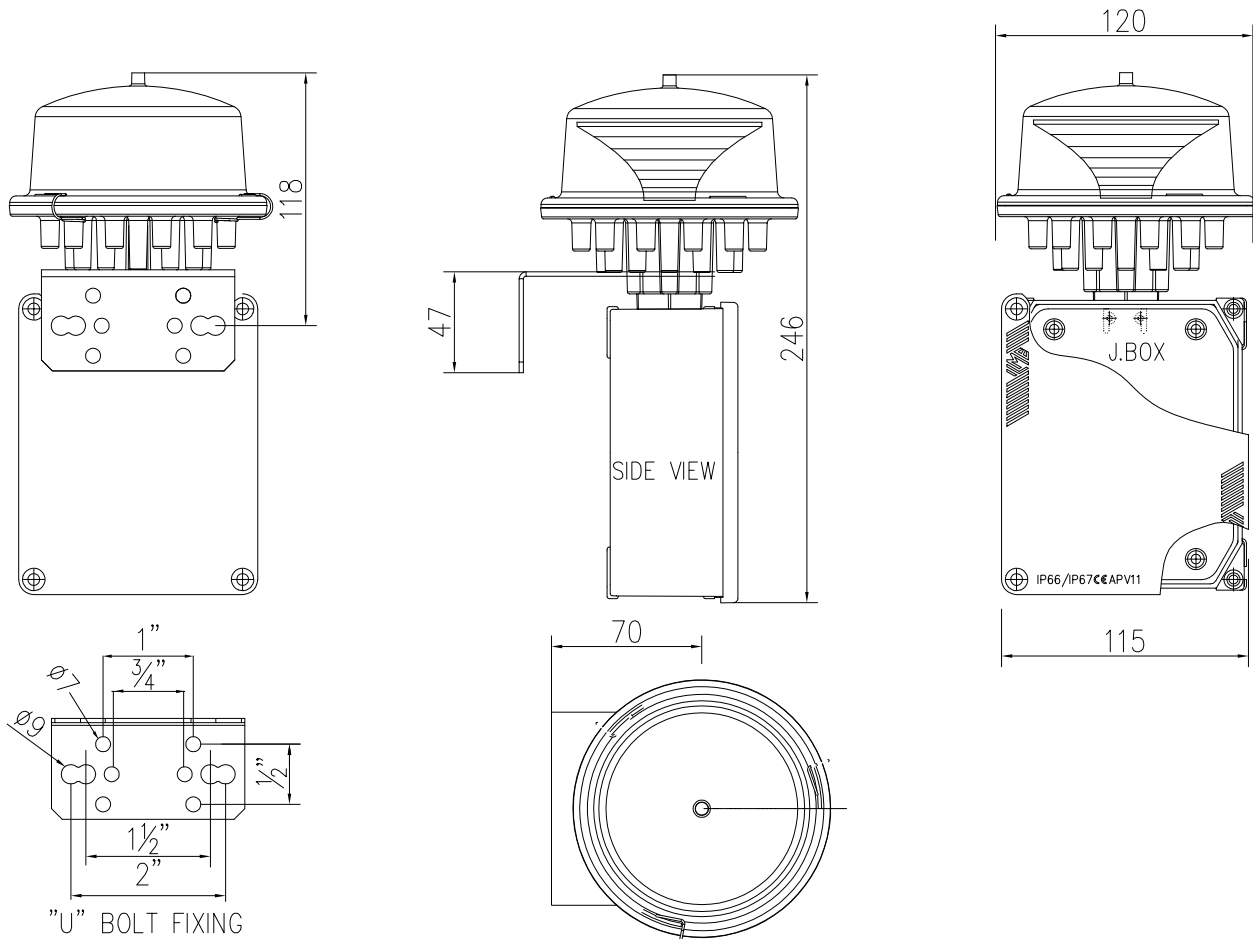



# MARINE NAVIGATION AIDS

## PRODUCT LINE TYPICAL INSTALLATION SURFACE LEVEL MARINE NAVIGATION AIDS

SAFE AREA IP66

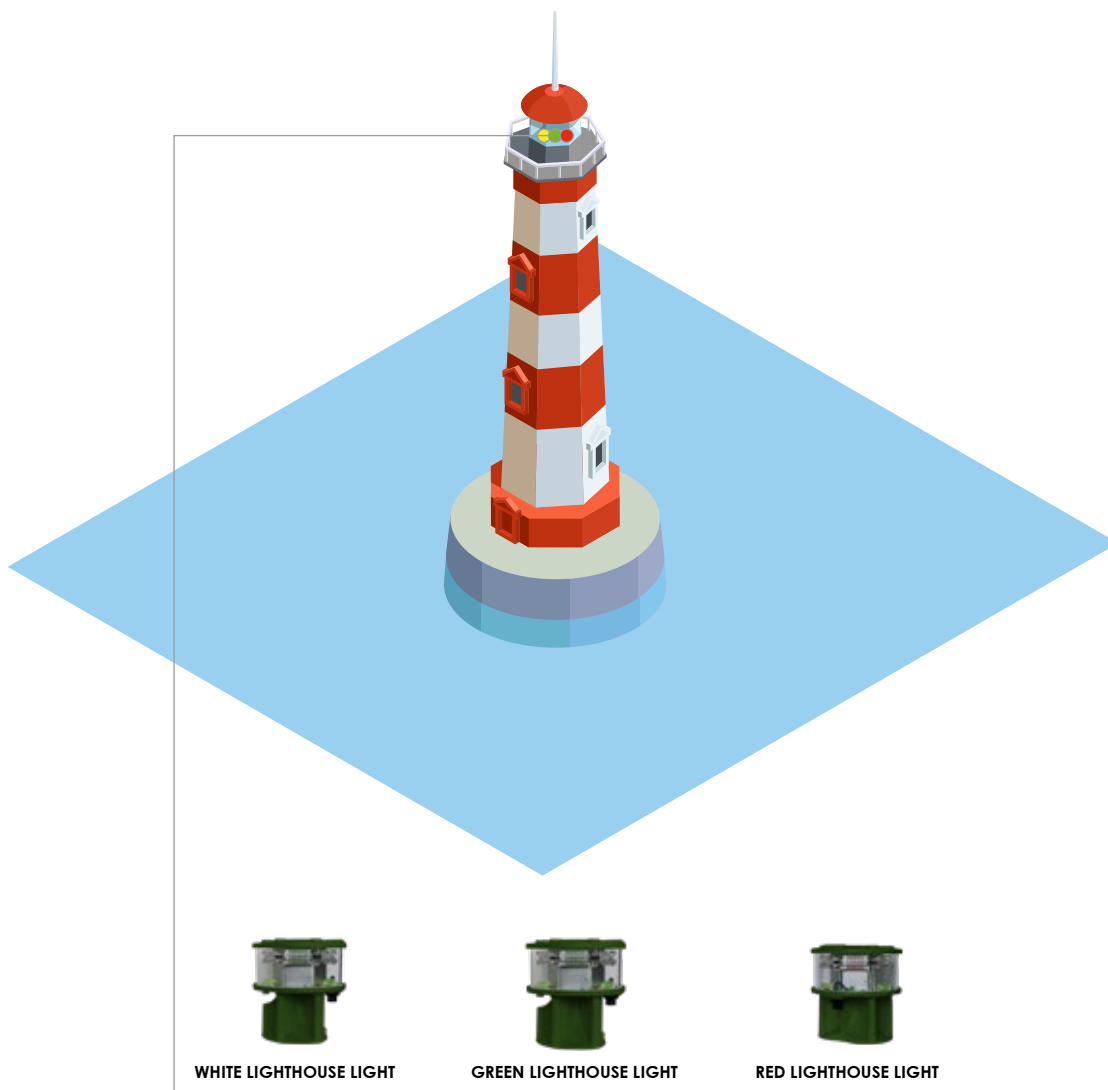

### LEGEND

 WHITE LIGHTHOUSE LIGHT

 RED LIGHTHOUSE LIGHT

 GREEN LIGHTHOUSE LIGHT

Image is for informational purposes only.

## WHITE LIGHTHOUSE LIGHT

SAFE AREA IP66



# LIGHTHOUSE LIGHTS

## WHITE LIGHTHOUSE LIGHT TECHNICAL SPECIFICATIONS

### KEY FEATURES

- Based on LED technology
- Night mode, white flashing (Isophase or occulting)
- Long life time >10+ years life expectancy
- Low consumption
- Stabilised light output
- Lightweight and compact
- Low wind load factor
- Alarm/remote status control
- Easy to install
- No RF-radiations
- Light output alignment device

### OPTICAL FEATURES

- Horizontal beam radiation 360°
- PMMA lens
- Luminous range for 74% (0,74T) atmospheric transmissivity

### OPTIONS

- Twin version: two galvanically separated circuits in the same fixture
- Anti bird protection
- Beacon support bracket
- Power supply AC or DC
- GPS (Global Position System) syncro
- Available with solar battery system
- Available for 7nM, 10nM, 12nM, 17nM

### ELECTRICAL FEATURES

- Average power consumption for isophase flashing (ISO W): 25W
- Average power consumption for occulting flashing (Oc. W): from 30W to 50W
- LED feeded at constant current
- Lightning protection

### MECHANICAL FEATURES

- Anodised aluminium body with heat-sink for natural draft air cooling
- RAL7035 painted aluminium body lamp
- Bottom wind collector for central heat-sink cooling
- Borosilicate glass cover protection
- Silicon gasket
- Degree of protection: IP65
- Operating temperature: -50°C to +80°C
- Storage temp. range: -20°C to +45°C
- Lamp unit weight: 6kg

### APPLY TO

- Lighthouse:
  - White light is used to identify navigational beacons (W)

### INTERNATIONAL REGULATION

- IALA Maritime Buoyage System and other aids to navigation
- IALA guideline No. 1049, Edition 2, December 2007
- CE marking

# LIGHTHOUSE LIGHTS

## WHITE LIGHTHOUSE LIGHT

### ORDER CODE

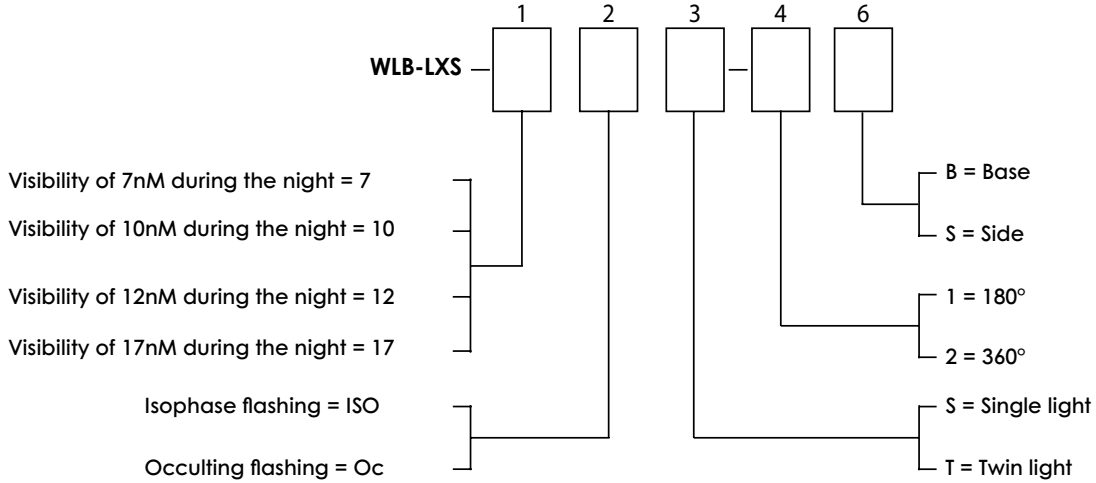

### BASE APPLICATION

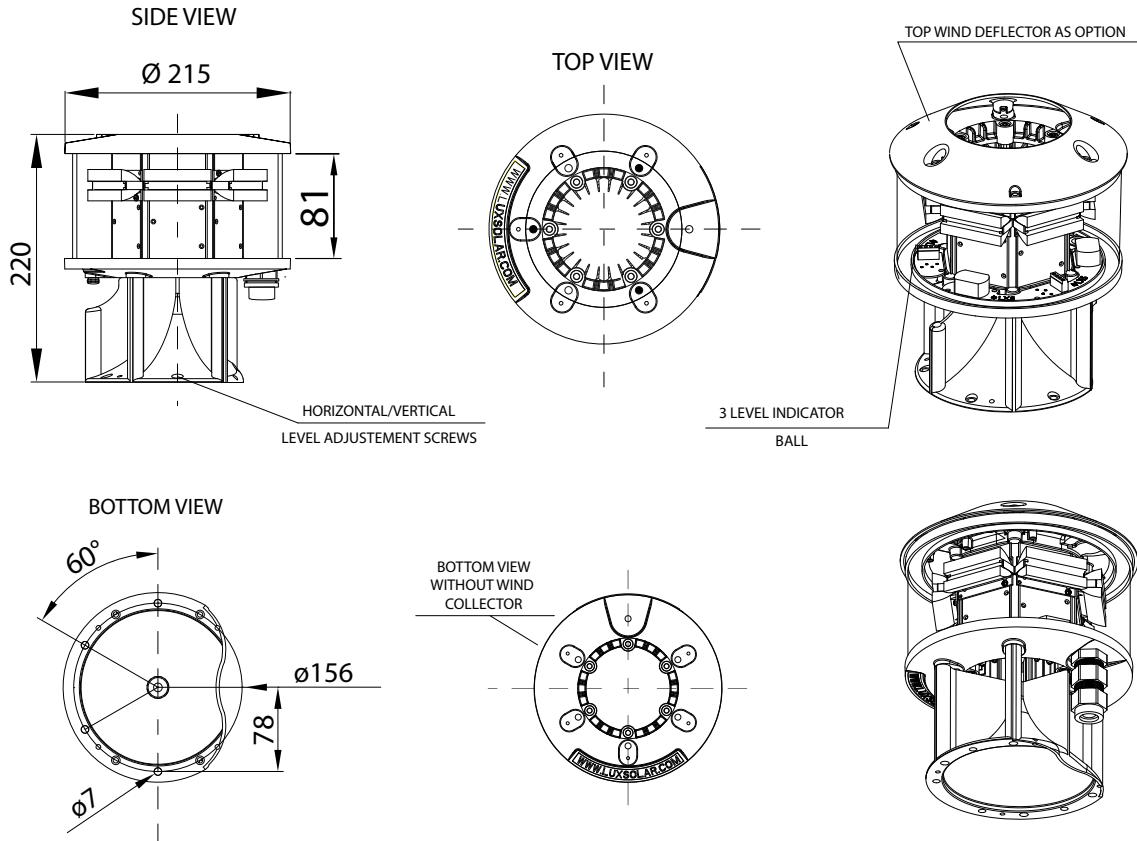



# LIGHTHOUSE LIGHTS

## WHITE LIGHTHOUSE LIGHT

### SIDE TYPE INSTALLATION

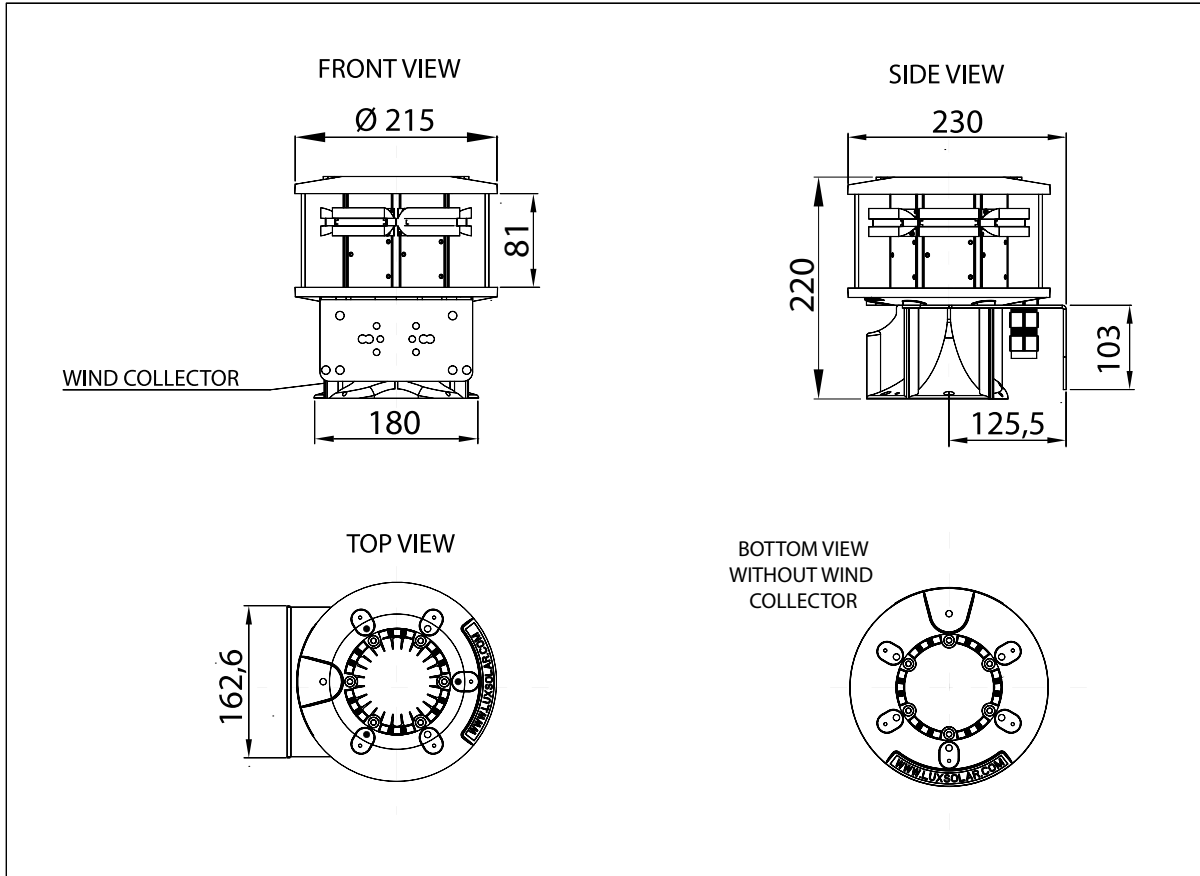

### CERTIFICATIONS



### FEATURES

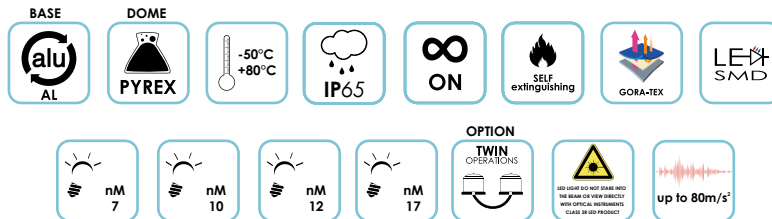

### TYPICAL APPLICATION



## GREEN LIGHTHOUSE LIGHT

SAFE AREA IP66



# LIGHTHOUSE LIGHTS

## GREEN LIGHTHOUSE LIGHT TECHNICAL SPECIFICATIONS

### KEY FEATURES

- Based on LED technology
- Night mode, green flashing (Isophase or occulting)
- Long life time >10 years life expectancy
- Low consumption
- Stabilised light output
- Lightweight and compact
- Low wind load factor
- Alarm/remote status control
- Easy to install
- No RF-radiations
- Light output alignment device

### OPTICAL FEATURES

- Horizontal beam radiation 360°
- PMMA lens
- Luminous range for 74% (0,74T) atmospheric transmissivity

### OPTIONS

- Twin version: two galvanically separated circuits in the same fixture
- Anti bird protection
- Beacon support bracket
- Power supply AC or DC
- GPS (Global Position System) syncro
- Available with solar battery system
- Available for 7nM, 10nM, 12nM, 17nM

### ELECTRICAL FEATURES

- Average power consumption for isophase flashing (ISO W): 25W
- Average power consumption for occulting flashing (Oc. W): from 30W to 50W
- LED feeded at constant current
- Lightning protection

### MECHANICAL FEATURES

- Anodised aluminium body with heat-sink for natural draft air cooling
- RAL7035 painted aluminium body lamp
- Bottom wind collector for central heat-sink cooling
- Borosilicate glass cover protection
- Silicon gasket
- Degree of protection: IP65
- Operating temperature: -50°C to +80°C
- Storage temp. range: -20°C to +45°C
- Lamp unit weight: 6kg

### APPLY TO

- Lighthouse:
  - Green light is used to identify safe waters (G)
  - Green light is used to identify the port (left) side of a channel (G)

### INTERNATIONAL REGULATION

- IALA Maritime Buoyage System and other aids to navigation
- IALA guideline No. 1049, Edition 2, December 2007
- CE marking

# LIGHTHOUSE LIGHTS

## GREEN LIGHTHOUSE LIGHT

### ORDER CODE

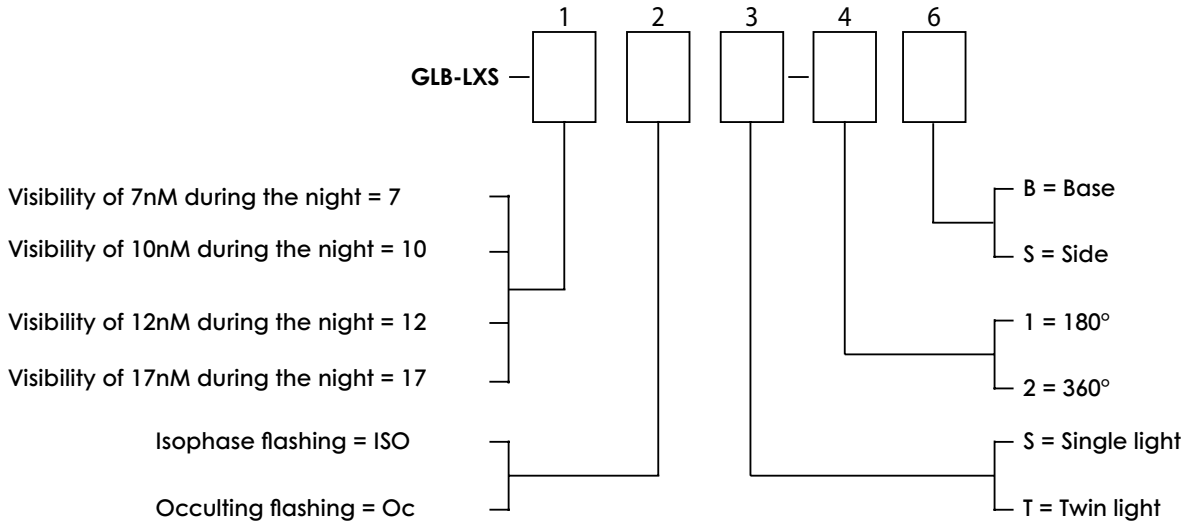

### BASE APPLICATION

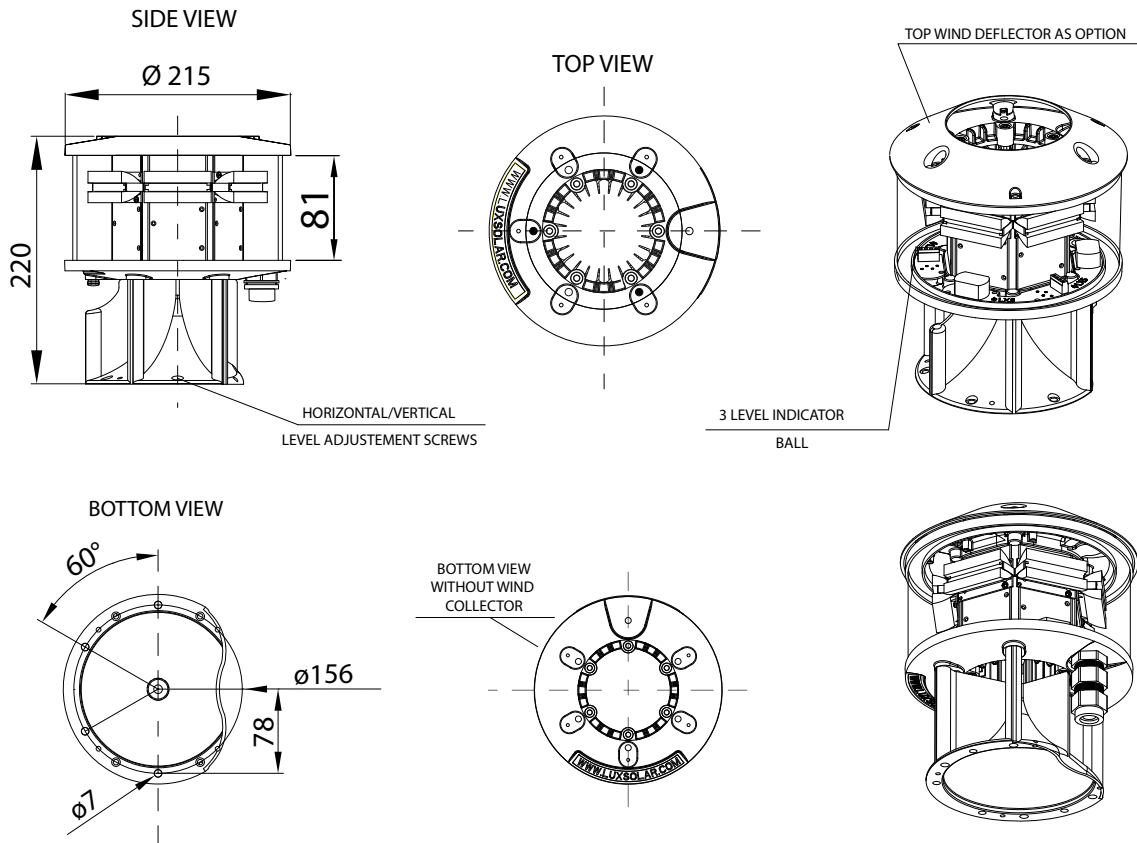

# LIGHTHOUSE LIGHTS

## GREEN LIGHTHOUSE LIGHT

### SIDE TYPE INSTALLATION

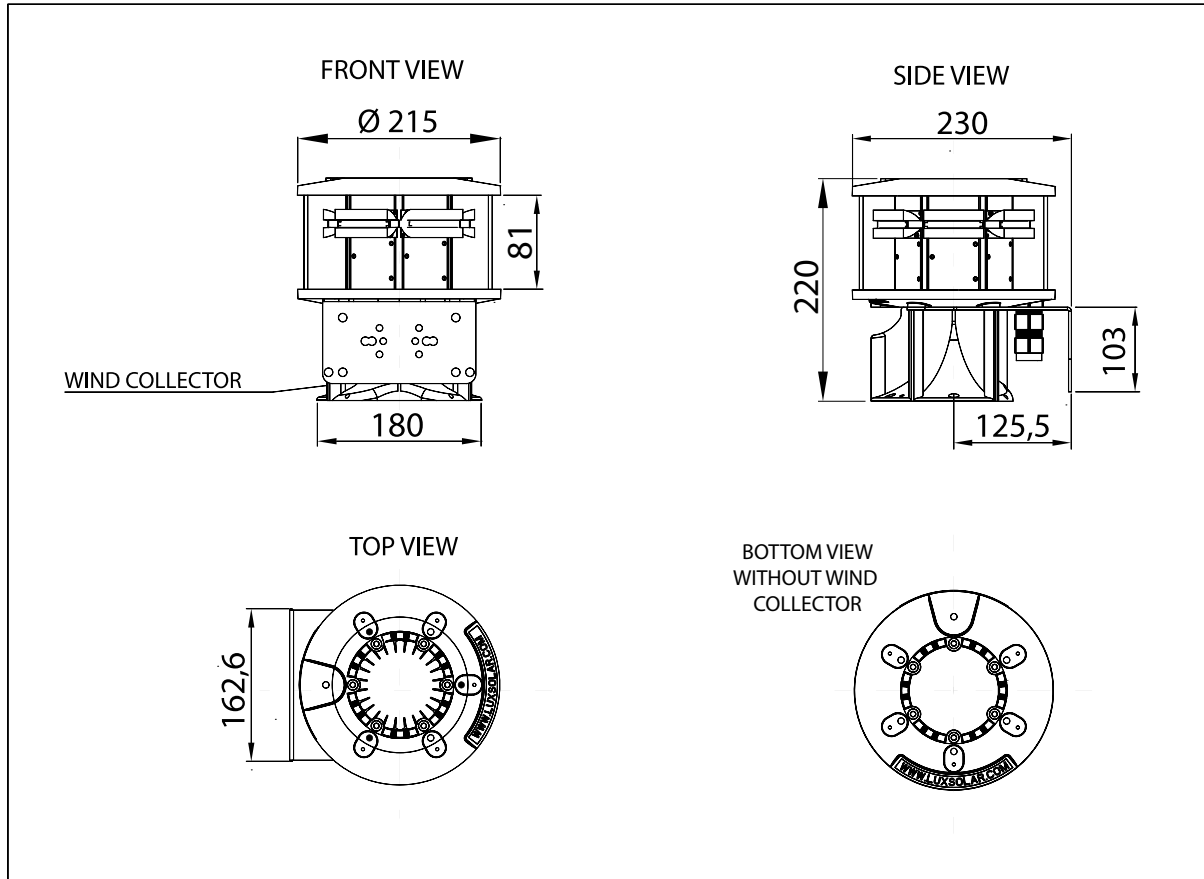

### CERTIFICATIONS



### FEATURES



### TYPICAL APPLICATION



## RED LIGHTHOUSE-DOCK LIGHT 12-17nM

SAFE AREA IP66



# LIGHTHOUSE-DOCK LIGHTS

## RED LIGHTHOUSE-DOCK LIGHT 12-17nM TECHNICAL SPECIFICATIONS

### KEY FEATURES

- Based on LED technology
- Night mode, red flashing (Isophase or occulting)
- Long life time >10+ years life expectancy
- Low consumption
- Stabilised light output
- Lightweight and compact
- Low wind load factor
- Alarm/remote status control
- Easy to install
- No RF-radiations
- Light output alignment device

### ELECTRICAL FEATURES

- Average power consumption for isophase flashing (ISO W): 25W
- Average power consumption for occulting flashing (Oc. W): from 30W to 50W
- LED feeded at constant current
- Lightning protection surge arrester

### OPTICAL FEATURES

- Horizontal beam radiation 360° or 180°
- PMMA lens
- Light intensity for luminous range for 74% (0,74T) atmospheric transmissivity

### OPTIONS

- Twin version: two galvanically separated circuits in the same fixture
- Anti bird protection
- Beacon support bracket
- Power supply AC or DC
- GPS (Global Position System) syncro
- Available with solar battery system
- Available for 7nM, 10nM, 12nM, 17nM

### MECHANICAL FEATURES

- Anodised aluminium body with heat-sink for natural draft air cooling
- RAL7035 painted aluminium body lamp
- Bottom wind collector for central heat-sink cooling
- Borosilicate glass cover protection
- Silicon gasket
- Degree of protection: IP66
- Operating temperature: -50°C to +80°C
- Storage temp. range: -20°C to +45°C
- Lamp unit weight: 6kg

### APPLY TO

- Lighthouse:
  - ° Red light is used to identify dangerous areas and warn ships that the waters are not safe (R)
  - ° Red light is used to identify the starboard (right) side of a channel (R)

### INTERNATIONAL REGULATION

- IALA Maritime Buoyage System and other aids to navigation
- IALA guideline No. 1049, Edition 2, December 2007
- CE marking

# LIGHTHOUSE-DOCK LIGHTS

## RED LIGHTHOUSE-DOCK LIGHT 12-17nM

### ORDER CODE

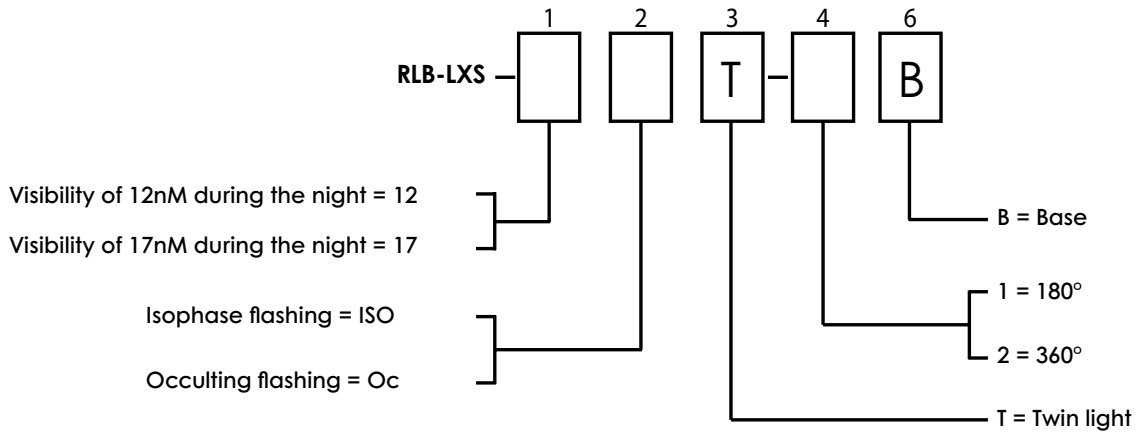

### BASE APPLICATION

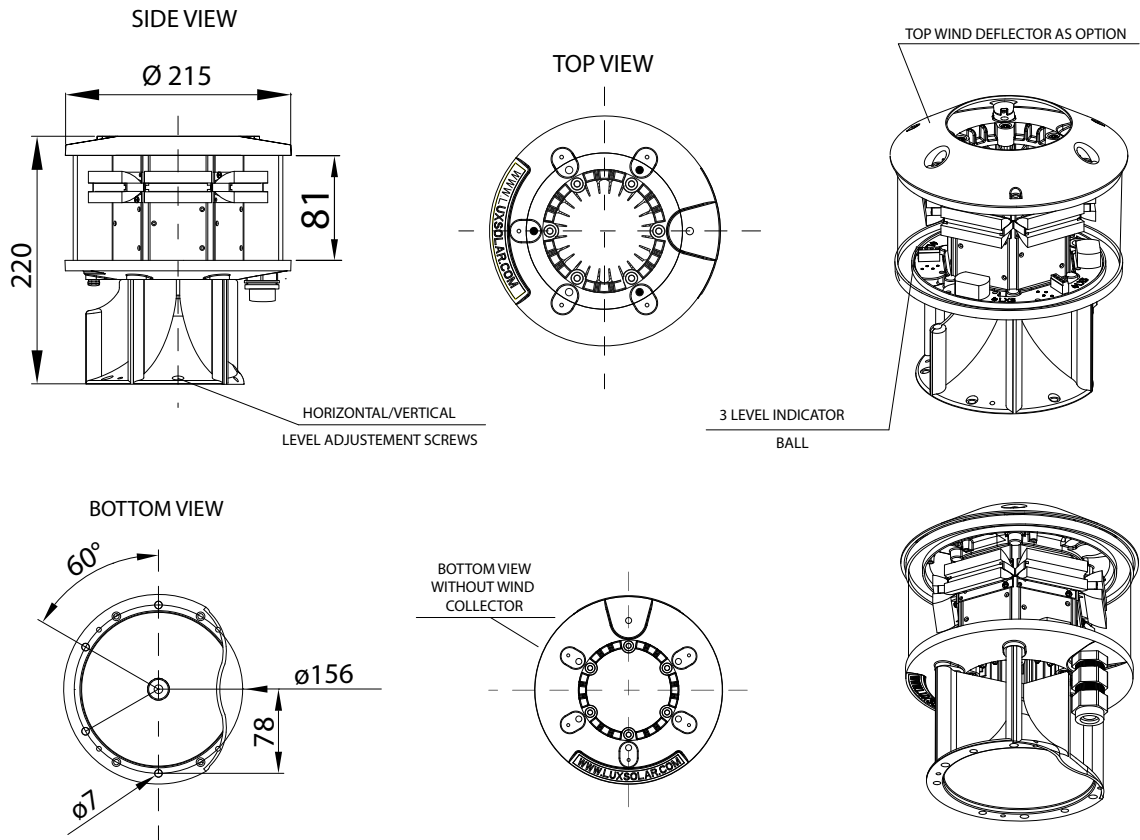



# LIGHTHOUSE-DOCK LIGHTS

## RED LIGHTHOUSE-DOCK LIGHT 12-17nM

### SIDE TYPE INSTALLATION

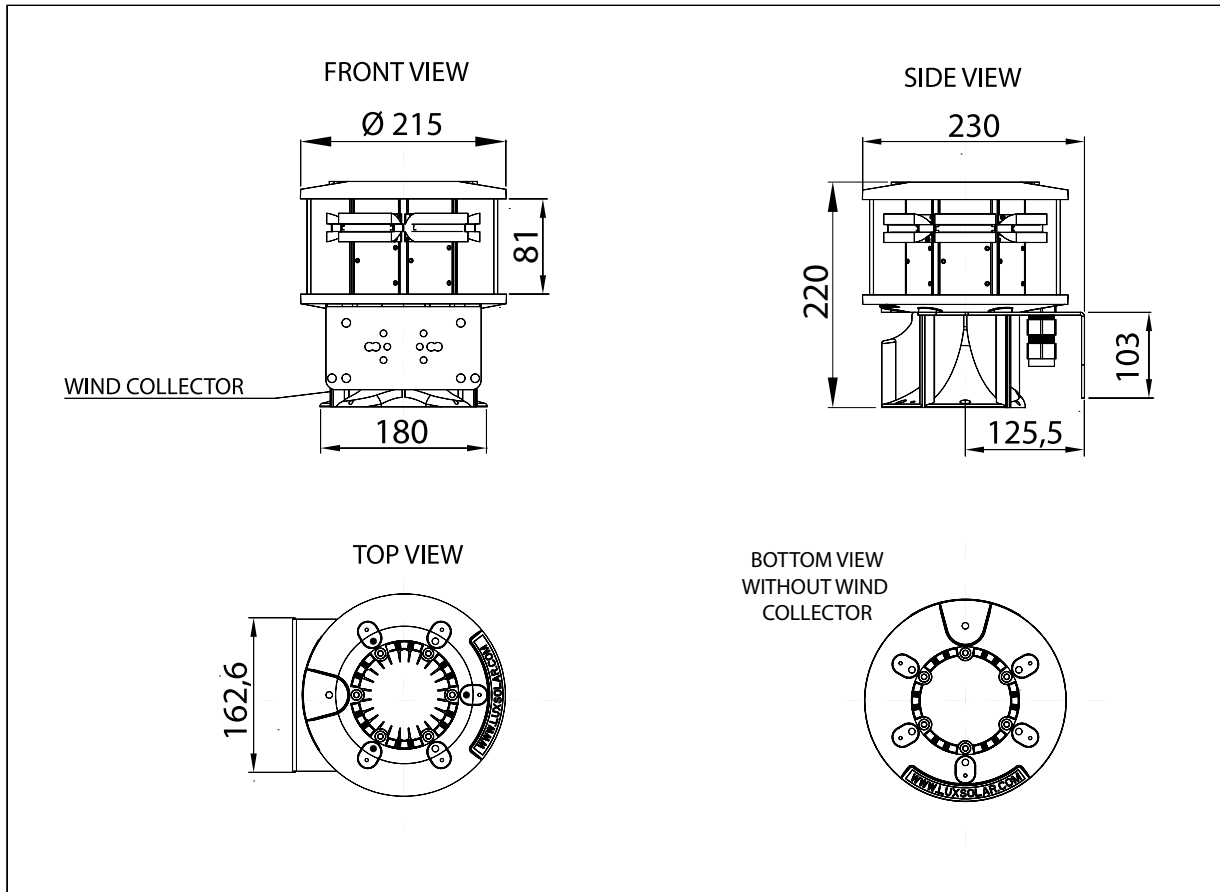

### CERTIFICATIONS



### COMPLIANCE



### FEATURES



### TYPICAL APPLICATION





# MARINE NAVIGATION AIDS

## PRODUCT LINE TYPICAL INSTALLATION SURFACE LEVEL MARINE NAVIGATION AIDS



EXPLOSION PROOF AREA

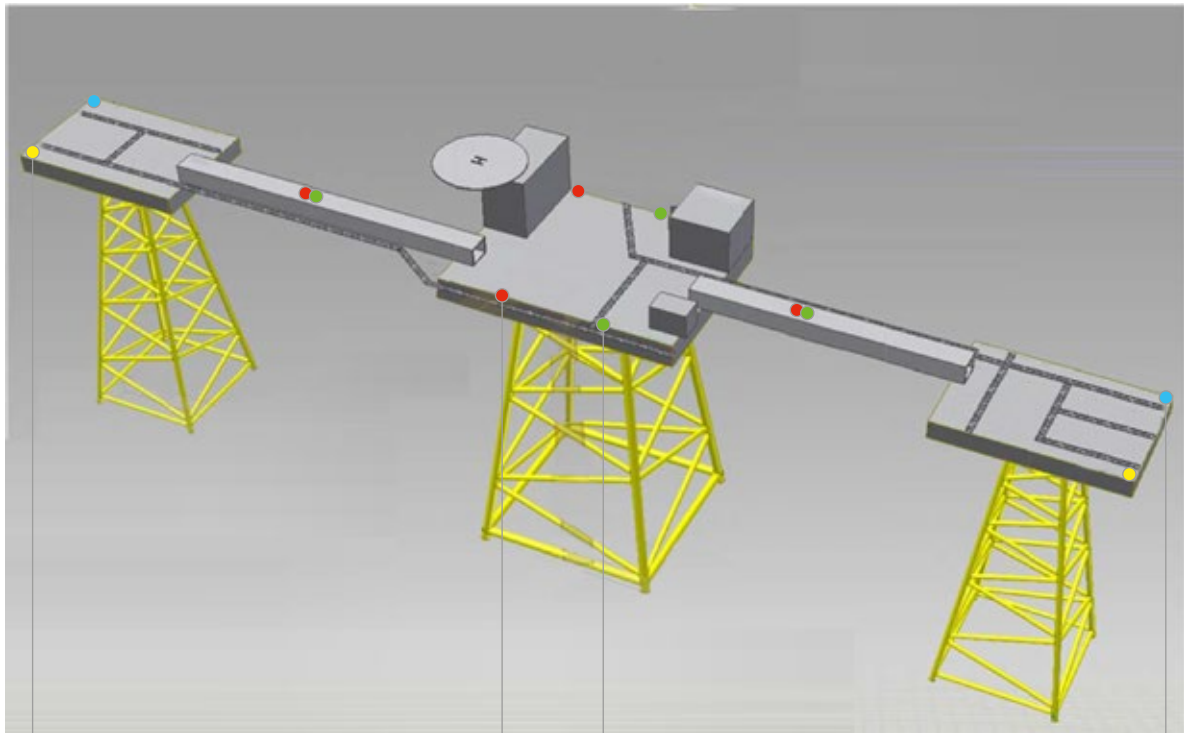

15NM WHITE LIGHT EX NIGHT MODE



5NM RED LIGHT EX NIGHT MODE



3NM RED LIGHT EX NIGHT MODE



10NM WHITE LIGHT EX NIGHT MODE



### LEGEND



15NM WHITE LIGHT EX NIGHT MODE



5NM RED LIGHT EX NIGHT MODE



10NM WHITE LIGHT EX NIGHT MODE



3NM RED LIGHT EX NIGHT MODE

Image is for informational purposes only.

## 15nM WHITE LIGHT Ex NIGHT MODE



HAZARDOUS AREA



# MARINE NAVIGATION AIDS

## 15nM WHITE LIGHT Ex NIGHT MODE TECHNICAL SPECIFICATIONS

### OPTICAL FEATURES

- Based on LED technology
- 15nM (nautical mile) night mode, WHITE flashing (Morse Letter "U")
- Horizontal beam radiation 360°
- Vertical beam spread >2,5°
- PMMA lens

### MECHANICAL FEATURES

- Painted RAL 7035 aluminium body
- Borosilicate glass dome
- Degree of protection: IP66
- Operating temperature: -52°C to +60°C
- Lamp unit weight: 15kg
- ATEX marking:  
II 2GD Ex de IIC T4 Gb, Ex tb IIIC T135°C Db
- IECEx marking:  
Ex de IIC T4 Gb, Ex tb IIIC T135°C Db
- TRCU RU marking:  
1 Ex db e IIC T6...T3 GbX,  
Ex tb IIIC T135°C...T200°C Db X

### ELECTRICAL FEATURES

- Power supply from LUXSOLAR control panel (to be purchased separately)
- Average power consumption 18W
- LED feeded at constant current

### APPLY TO

- Oil&Gas platform
- Other individual structure
- Used as main light to ensure that at least one light is visible upon approaching the structure from any direction

### CERTIFICATIONS

- ATEX certificate
- IECEx certificate
- TRCU certificate
- CE marking
- IALA Maritime Buoyage System (MBS)
- IALA Recommendation O-139

### PART NUMBER

- Part number:  
▶ **MNL-LXS-15nM-Ex-8**

# MARINE NAVIGATION AIDS

## 15nM WHITE LIGHT Ex NIGHT MODE TECHNICAL DRAWINGS

BEACON FRONT VIEW

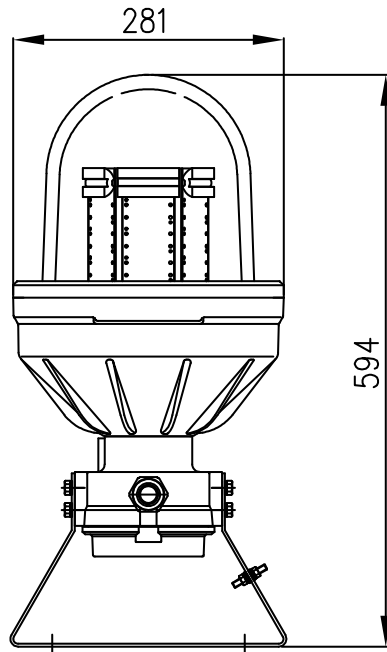

BEACON SIDE VIEW

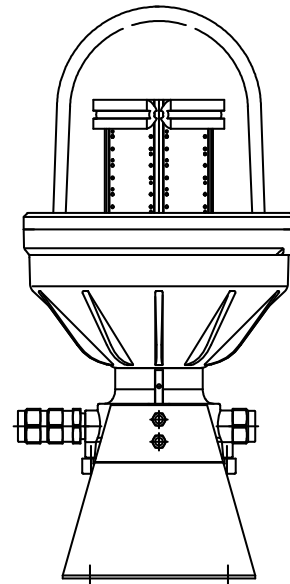

FIXING DETAILS

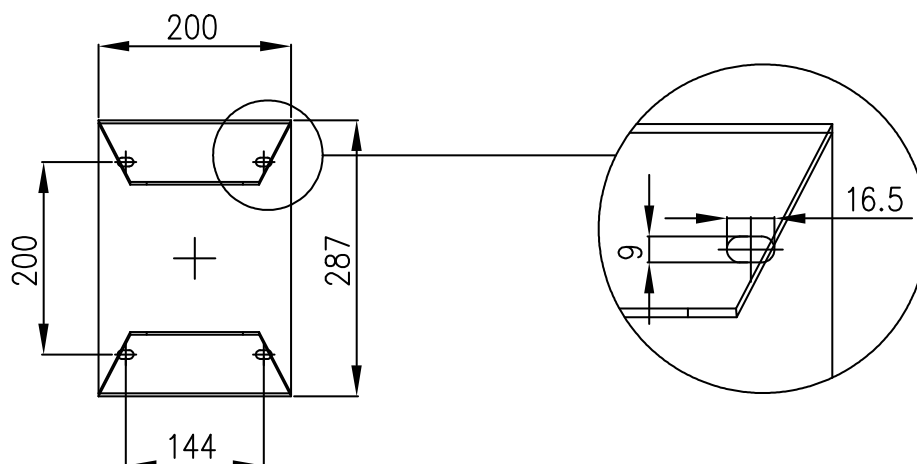

# MARINE NAVIGATION AIDS

## 15nM WHITE LIGHT Ex NIGHT MODE

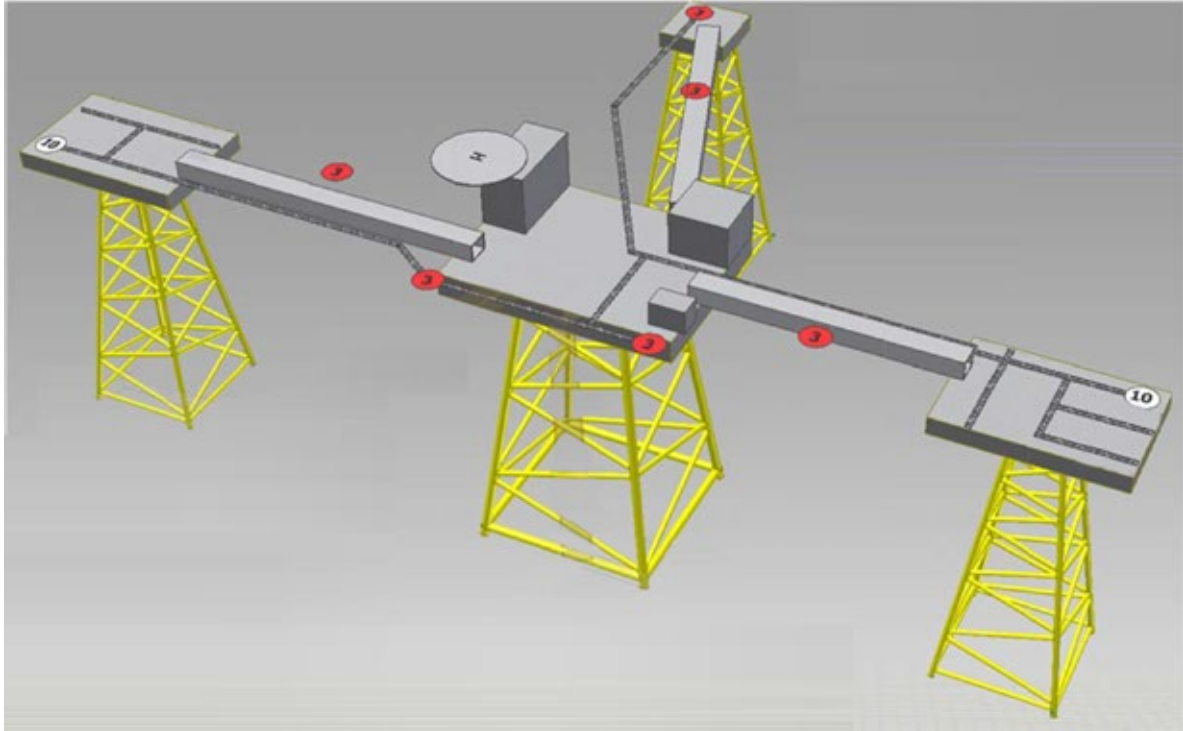

LEGEND
⑮ 15nM - White

### CERTIFICATIONS



### FEATURES



### TYPICAL APPLICATION



## 10nM WHITE LIGHT Ex NIGHT MODE



HAZARDOUS AREA





# MARINE NAVIGATION AIDS

## 10nM WHITE LIGHT Ex NIGHT MODE TECHNICAL SPECIFICATIONS

### OPTICAL FEATURES

- Based on LED technology
- 10nM (nautical mile) night mode, WHITE flashing (Morse Letter "U")
- Horizontal beam radiation 360°
- Vertical beam spread >2,5°
- PMMA lens

### MECHANICAL FEATURES

- Painted RAL 7035 aluminium body
- Borosilicate glass dome
- Degree of protection: IP66
- Operating temperature: -52°C to +60°C
- Lamp unit weight: 15kg
- ATEX marking:  
II 2GD Ex de IIC T4 Gb, Ex tb IIIC T135°C Db
- IECEx marking:  
Ex de IIC T4 Gb, Ex tb IIIC T135°C Db
- TRCU RU marking:  
1 Ex db e IIC T6...T3 GbX,  
Ex tb IIIC T135°C...T200°C Db X

### ELECTRICAL FEATURES

- Power supply from LUXSOLAR control panel (to be purchased separately)
- Average power consumption 6W
- LED feeded at constant current

### APPLY TO

- Oil&Gas platform
- Other individual structure
- Used as main light to ensure that at least one light is visible upon approaching the structure from any direction

### CERTIFICATIONS

- ATEX certificate
- IECEx certificate
- TRCU certificate
- CE marking
- IALA Maritime Buoyage System (MBS)
- IALA Recommendation O-139

### PART NUMBER

- Part number:  
▶ **MNL-LXS-10nM-Ex-8**

# MARINE NAVIGATION AIDS

## 10nM WHITE LIGHT Ex NIGHT MODE TECHNICAL DRAWINGS

BEACON FRONT VIEW

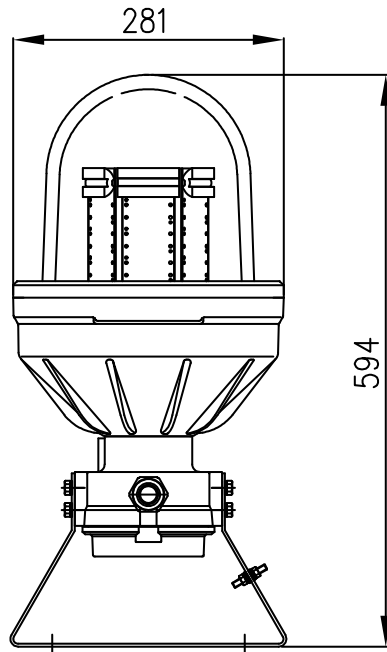

BEACON SIDE VIEW

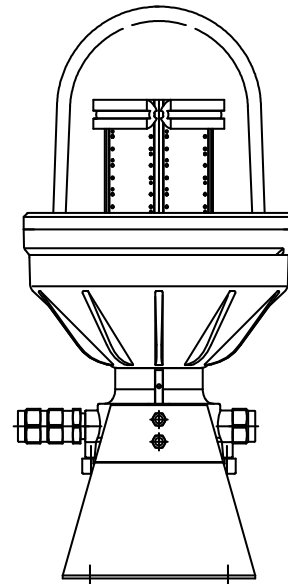

FIXING DETAILS

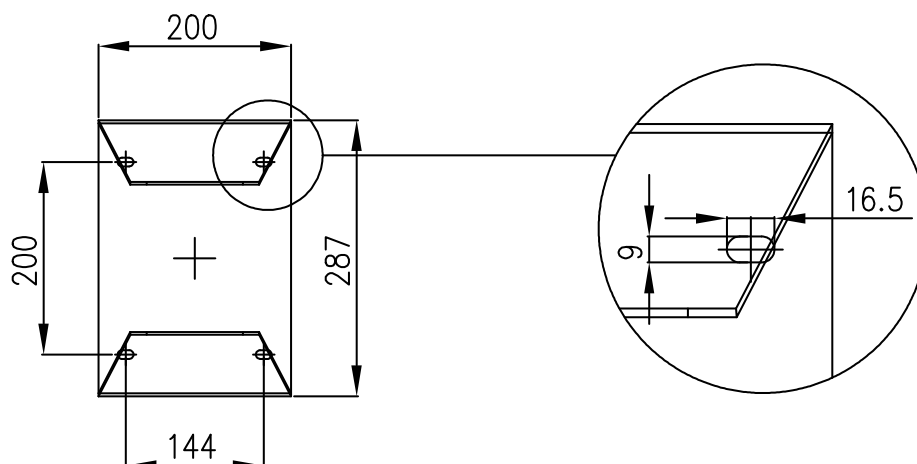

# MARINE NAVIGATION AIDS

## 10nM WHITE LIGHT Ex NIGHT MODE

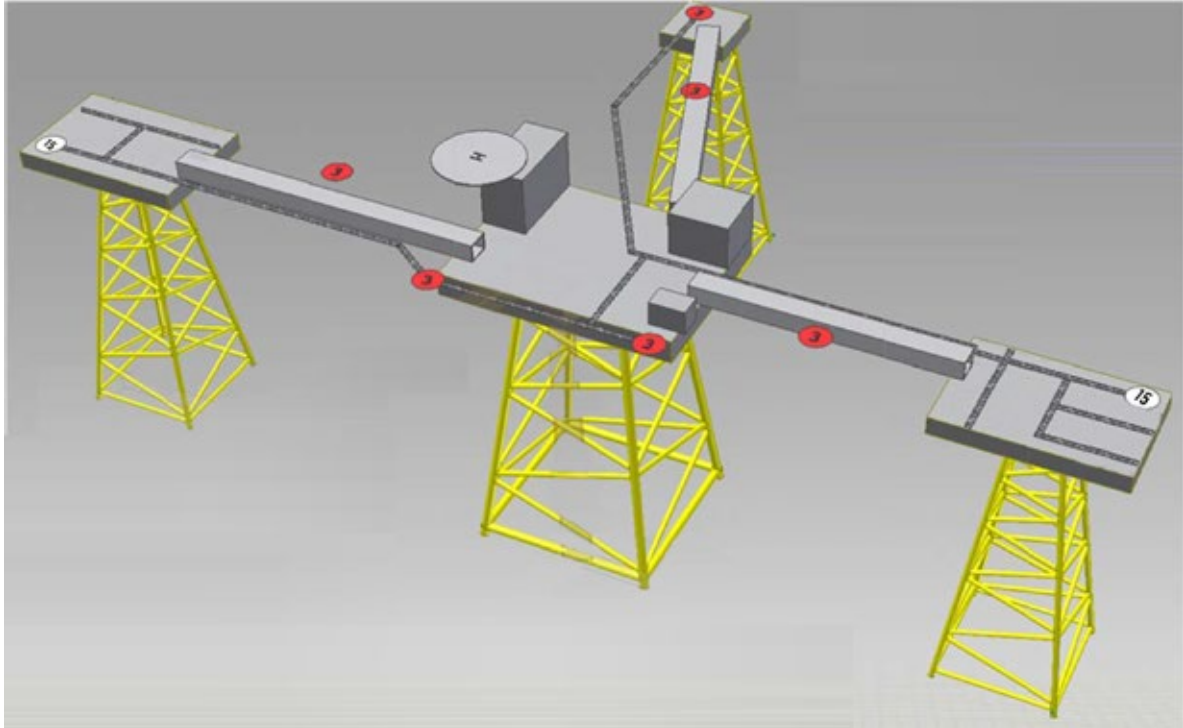

### LEGEND

⑩ 10nM - White

### CERTIFICATIONS



### FEATURES



### TYPICAL APPLICATION



## 5nM RED LIGHT Ex NIGHT MODE



HAZARDOUS AREA



# MARINE NAVIGATION AIDS

## 5nM RED LIGHT Ex NIGHT MODE TECHNICAL SPECIFICATIONS

### OPTICAL FEATURES

- Based on LED technology
- 5nM (nautical mile) night mode, red flashing (Morse Letter "U")
- Horizontal beam radiation 360°
- Vertical beam spread >2,5°
- PMMA lens

### MECHANICAL FEATURES

- Painted RAL 7035 aluminium body
- Borosilicate glass dome
- Degree of protection: IP66
- Operating temperature: -52°C to +60°C
- Lamp unit weight: 7kg
- ATEX marking:  
II 2GD Ex de IIC T4 Gb, Ex tb IIIC T135°C Db
- IECEx marking:  
Ex de IIC T4 Gb, Ex tb IIIC T135°C Db
- TRCU RU marking:  
1 Ex db e IIC T6...T3 GbX,  
Ex tb IIIC T135°C...T200°C Db X

### ELECTRICAL FEATURES

- Power supply AC or DC or from Luxsolar Control Panel
- Average power consumption for night mode: 4W
- LED feeded at constant current

### APPLY TO

- Oil&Gas platform  
Use as subsidiary light located to mark the horizontal extremities of the structure excepting those mark with white lights as well as interconnecting bridges.

### CERTIFICATIONS

- ATEX certificate
- IECEx certificate
- TRCU certificate
- CE marking
- IALA Maritime Buoyage System (MBS)
- IALA Recommendation O-139

### PART NUMBER

- Part number:
  - ▶ **MNL-LXS-5nM-Ex-230VAC**
  - ▶ **MNL-LXS-5nM-Ex-24VDC**

# MARINE NAVIGATION AIDS

## 5nM WHITE LIGHT Ex NIGHT MODE TECHNICAL DRAWINGS

BEACON FRONT VIEW

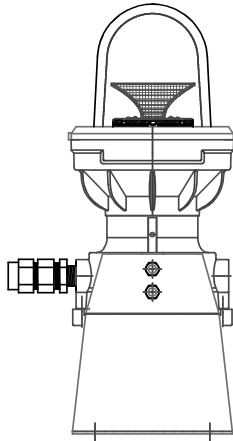

BEACON SIDE VIEW

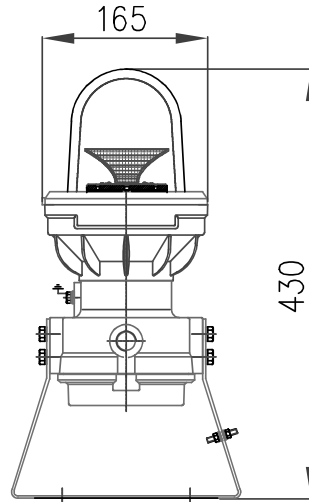

BEACON TOP VIEW

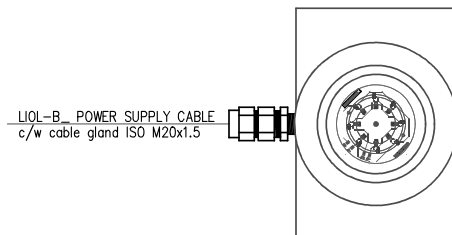

FIXING DETAILS

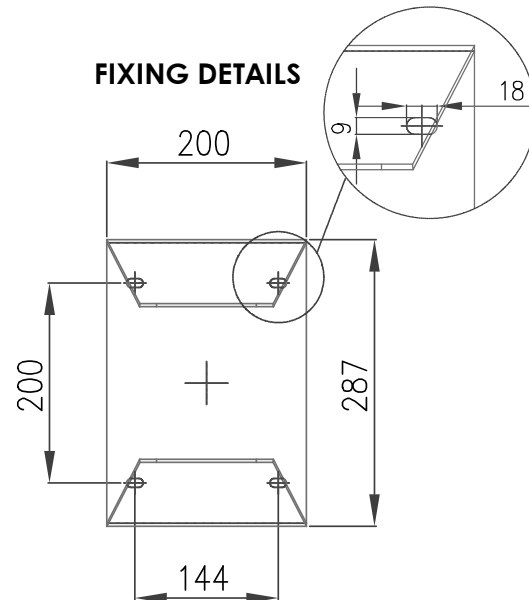

# MARINE NAVIGATION AIDS

## 5nM RED LIGHT Ex NIGHT MODE

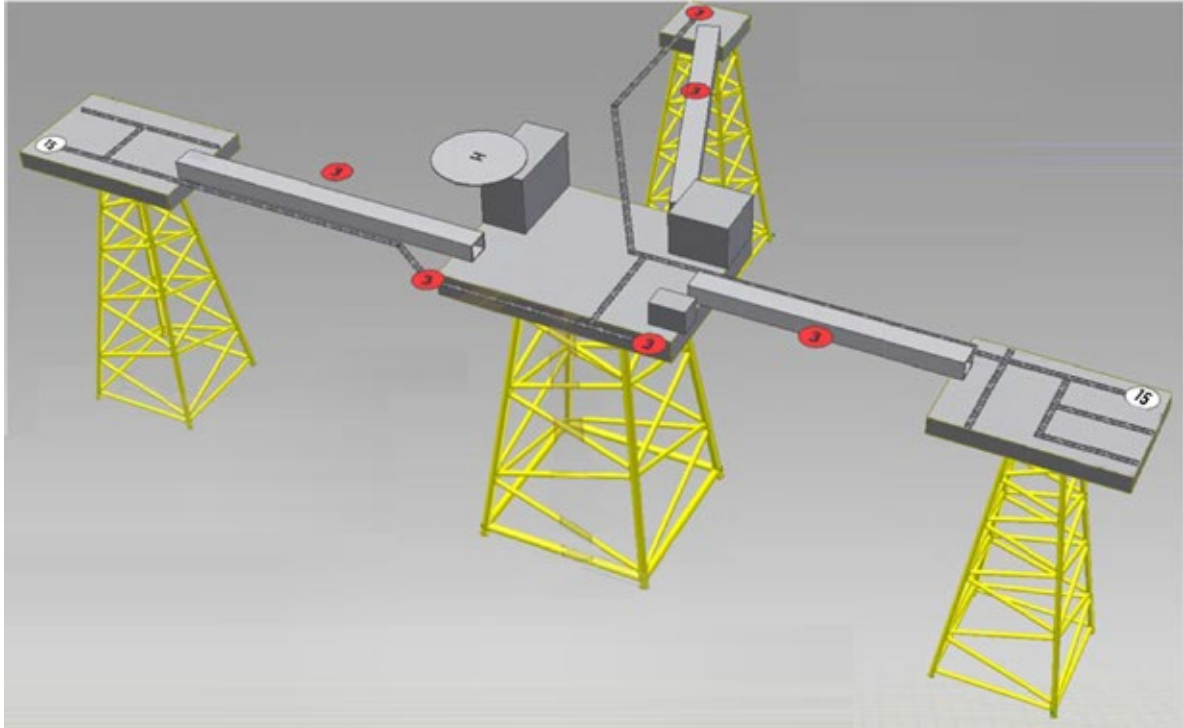

### LEGEND

5 5nM - Red

### CERTIFICATIONS



### FEATURES



### TYPICAL APPLICATION



## 3nM RED LIGHT Ex NIGHT MODE



HAZARDOUS AREA





# MARINE NAVIGATION AIDS

## 3nM RED LIGHT Ex NIGHT MODE TECHNICAL SPECIFICATIONS

### OPTICAL FEATURES

- Based on LED technology
- 3nM (nautical mile) night mode, red flashing (Morse Letter "U")
- Horizontal beam radiation 360°
- Vertical beam spread >2,5°
- PMMA lens

### MECHANICAL FEATURES

- Painted RAL 7035 aluminium body
- Borosilicate glass dome
- Degree of protection: IP66
- Operating temperature: -52°C to +60°C
- Lamp unit weight: 7kg
- ATEX marking:  
II 2GD Ex de IIC T4 Gb, Ex tb IIIC T135°C Db
- IECEx marking:  
Ex de IIC T4 Gb, Ex tb IIIC T135°C Db
- TRCU RU marking:  
1 Ex db e IIC T6...T3 GbX,  
Ex tb IIIC T135°C...T200°C Db X

### ELECTRICAL FEATURES

- Power supply AC or DC or from Luxsolar Control Panel
- Average power consumption for night mode: 2W
- LED feeded at constant current

### APPLY TO

- Oil&Gas platform  
Use as subsidiary light located to mark the horizontal extremities of the structure excepting those mark with white lights as well as interconnecting bridges.

### CERTIFICATIONS

- ATEX certificate
- IECEx certificate
- TRCU certificate
- CE marking
- IALA Maritime Buoyage System (MBS)
- IALA Recommendation O-139

### PART NUMBER

- Part number:
  - ▶ **MNL-LXS-3nM-Ex-230VAC**
  - ▶ **MNL-LXS-3nM-Ex-24VDC**

# MARINE NAVIGATION AIDS

## 3nM WHITE LIGHT Ex NIGHT MODE TECHNICAL DRAWINGS

BEACON FRONT VIEW

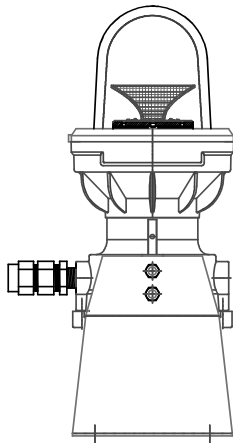

BEACON SIDE VIEW

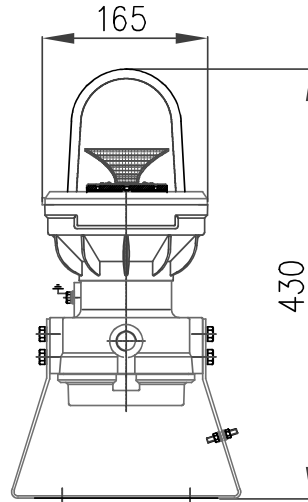

BEACON TOP VIEW

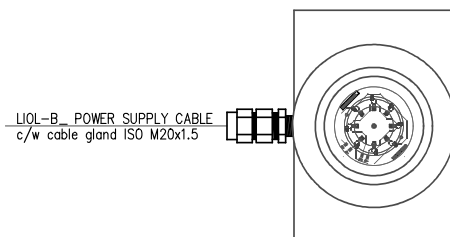

LIOL-B POWER SUPPLY CABLE  
c/w cable gland ISO M20x1.5

FIXING DETAILS

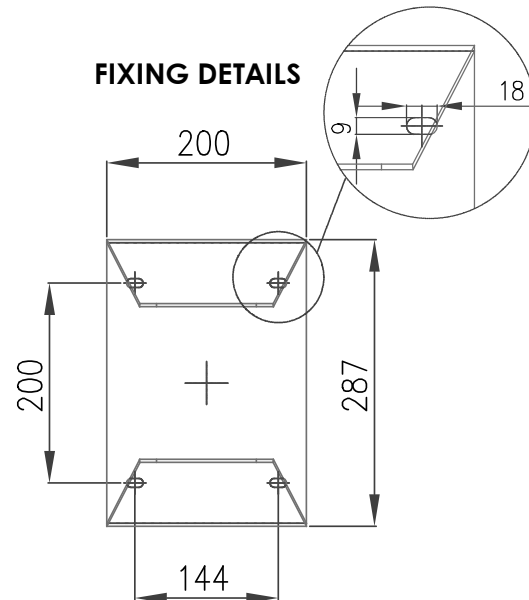

# MARINE NAVIGATION AIDS

## 3nM RED LIGHT Ex NIGHT MODE

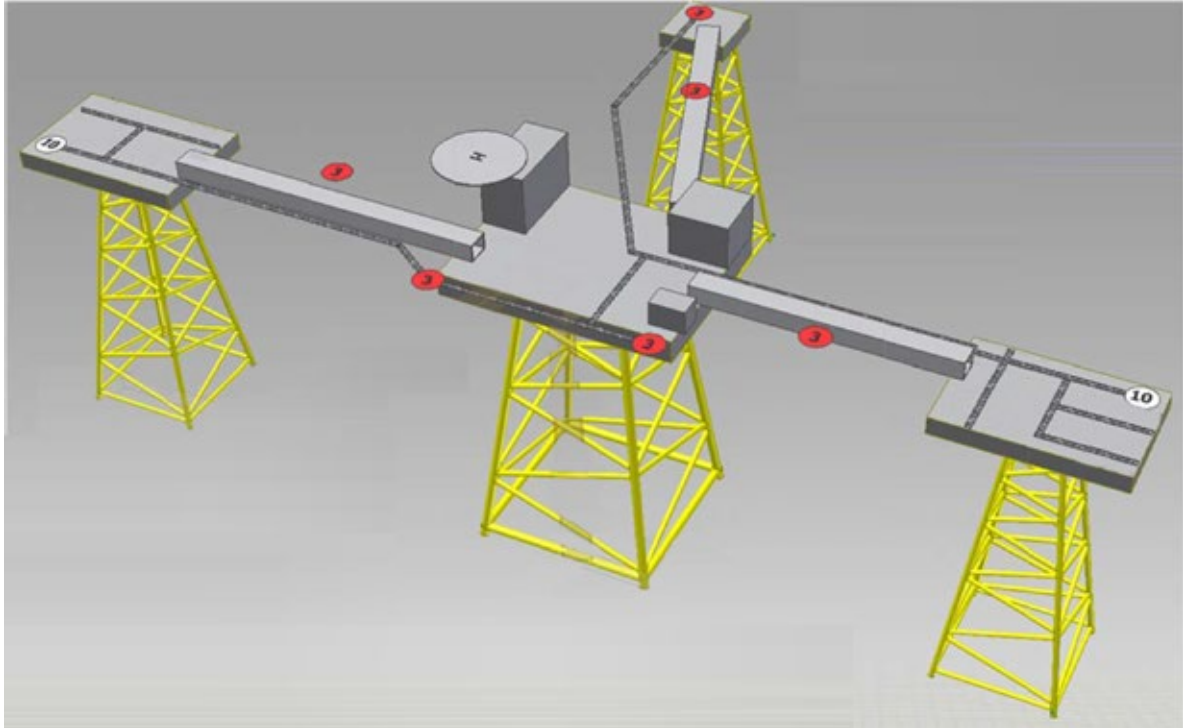

### LEGEND

③ 3nM - Red

### CERTIFICATIONS



### FEATURES



### TYPICAL APPLICATION









# CONTACTS

## **CE2K S.r.l. - Luxsolar®**

---

**Phone: +39 0341-260926**

**E-mail: [info@ce2k.com](mailto:info@ce2k.com) - [lx@luxsolar.com](mailto:lx@luxsolar.com)**

**Web sites: [www.ce2k.com](http://www.ce2k.com) - [www.luxsolar.com](http://www.luxsolar.com)**

- LinkedIn: Luxsolar Italia



- YouTube: Luxsolar





LUXSOLAR® is a department of CE2K S.r.l.  
Via Sabatelli 38, 23868 Valmadrera (LC) - Italy



[www.luxsolar.com](http://www.luxsolar.com)